

China Patient Lift Lieferant

MANUAL HYDRAULIC PATIENT LIFT



PRODUCT ADVANTAGES



450lb capacity



Thickened nylon sling



Heavy gauge steel
construction



Rear wheel brake

PRODUCT PARAMETER

Parameter	Category
Boom Height	17.5" - 72"
Base Width	42"(open) / 22.5" (closed)
Base Height	6.5"
Casters	5"
Weight	72 lbs.
Carton Shipping Weight	84 lbs.
Weight Limit	450 lbs.
Package Dimensions	126*65*35cm

PRODUCT STRUCTURE



PRODUCT STRUCTURE





360° ROTATE

Six point spreader bar with 360 degree rotation, Uses 6-point, 4-point slings .



STANDARD BASE

6.5 inch standard base design, the base can be installed under bed, wheelchair or furniture.



450LB CAPACITY

Provide a variety of environmentally friendly nylon slings, full body support and protection

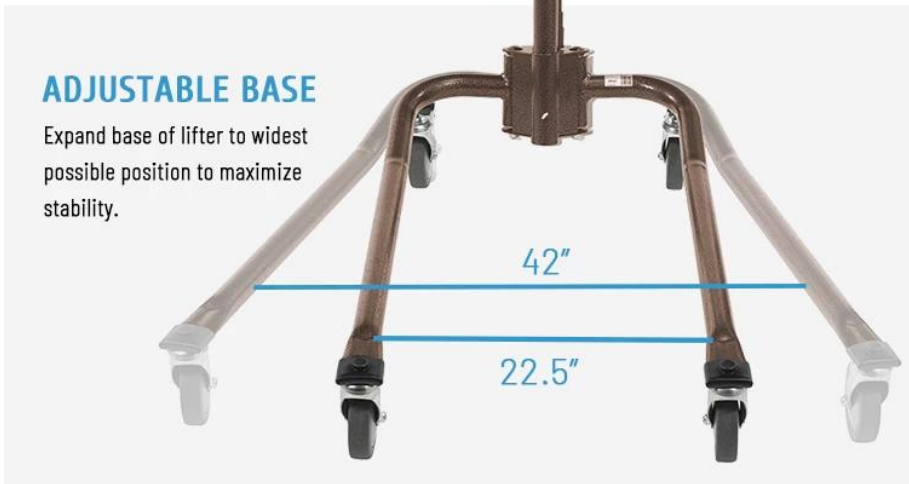

ADJUSTABLE BASE

Expand base of lifter to widest possible position to maximize stability.

REAR WHEEL DOUBLE BRAKE

Wheel locks are provided on two casters for parking To lock casters, step on cam lever on side of caster.

